

Digital Miniature Double-Ended Beam

FEATURES

- Easy corner compensation of the weighbridge
- Capacities: 10–30T
- Digital output via RS485 or RS422 interface
- High side load tolerance
- Electroless nickel-plated alloy tool steel
- Surge protection optional
- Extensive internal diagnostics
- External resolution 240,000 counts
- Internal resolution 1,000,000 counts
- Maximum transmission distance 1200m

APPLICATIONS

- Truck/rail scales
- Silo/hopper/tank weighing

DESCRIPTION

The MDBD is designed for truck and rail scales in high capacities with low profile. The design of loading through a ball is insensitive to side load.

The MDBD is constructed of alloy steel and is fully potted and sealed with special chemical compounds to IP67 providing excellent protection against water and moisture attack.



The digital output enables the user to communicate with each MDBD independently of the others in the system, thus offering advantages in system setup, system control, corner correction, fault finding and load cell replacement.

OUTLINE DIMENSIONS in millimeters

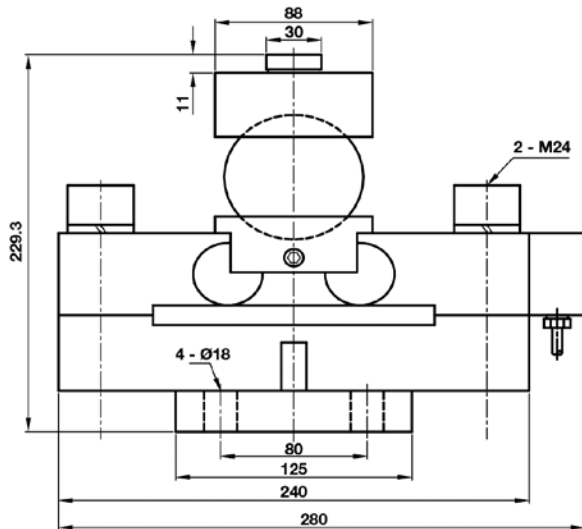

Cable specifications:

Cable length: 13.5m

Excitation +	Green
Excitation -	Black
Rx +	Yellow
Rx -	Blue
Tx +	Red
Tx -	White
Shield	Transparent

Digital Miniature Double-Ended Beam

SPECIFICATIONS		
PARAMETER	VALUE	UNIT
Standard capacities (E _{max})	10, 20, 25, 30	ton
Rated output—R.O.	240,000	counts
Rated output tolerance	200	±counts
Zero balance	200	±counts
Combined error	0.0200	±% of rated output
Non-repeatability	0.0200	±% of rated output
Creep error (30 minutes)	0.03	±% of rated output
Creep error (20–30 minutes)	0.01	±% of rated output
Zero return (30 minutes)	0.03	±% of rated output
Temperature effect on span	0.015	±% of rated output/10°C
Temperature effect on zero	0.026	±% of rated output/10°C
Compensated temperature range	-10 to +40	°C
Operating temperature range	-40 to +80	°C
Storage temperature range	-40 to +90	°C
Minimum dead load	0	% of E _{max}
Safe dead load	150	% of E _{max}
Ultimate load	300	% of E _{max}
Excitation voltage	12.5 to 18	VDC
Recommended excitation voltage	15	VDC
Maximum current consumption	80	mA
Start up current	150	mA
Insulation resistance	>5000	MW
Element material	Alloy steel	
Sealing (DIN 40.050/EN60.529/IEC 529)	IP67	
Signal update per second	25	
Baudrate	9600	Bits/s
Transmission type	Asynchronous serial transmission	
Start bits	1	
Data bits	7	
Stop bits	1	
Parity	Odd	
Maximum transmission cable length	1200	m
Data transmission interface	RS422 (4 communication wires)/ RS485 (2 communication wires)	

All specifications subject to change without notice.



Disclaimer

ALL PRODUCTS, PRODUCT SPECIFICATIONS AND DATA ARE SUBJECT TO CHANGE WITHOUT NOTICE.

Vishay Precision Group, Inc., its affiliates, agents, and employees, and all persons acting on its or their behalf (collectively, "VPG"), disclaim any and all liability for any errors, inaccuracies or incompleteness contained herein or in any other disclosure relating to any product.

The product specifications do not expand or otherwise modify VPG's terms and conditions of purchase, including but not limited to, the warranty expressed therein.

VPG makes no warranty, representation or guarantee other than as set forth in the terms and conditions of purchase. **To the maximum extent permitted by applicable law, VPG disclaims (i) any and all liability arising out of the application or use of any product, (ii) any and all liability, including without limitation special, consequential or incidental damages, and (iii) any and all implied warranties, including warranties of fitness for particular purpose, non-infringement and merchantability.**

Information provided in datasheets and/or specifications may vary from actual results in different applications and performance may vary over time. Statements regarding the suitability of products for certain types of applications are based on VPG's knowledge of typical requirements that are often placed on VPG products. It is the customer's responsibility to validate that a particular product with the properties described in the product specification is suitable for use in a particular application. You should ensure you have the current version of the relevant information by contacting VPG prior to performing installation or use of the product, such as on our website at vpgsensors.com.

No license, express, implied, or otherwise, to any intellectual property rights is granted by this document, or by any conduct of VPG.

The products shown herein are not designed for use in life-saving or life-sustaining applications unless otherwise expressly indicated. Customers using or selling VPG products not expressly indicated for use in such applications do so entirely at their own risk and agree to fully indemnify VPG for any damages arising or resulting from such use or sale. Please contact authorized VPG personnel to obtain written terms and conditions regarding products designed for such applications.

Product names and markings noted herein may be trademarks of their respective owners.

Copyright Vishay Precision Group, Inc., 2014. All rights reserved.