

Precision Shear Web Disk

FEATURES

- Capacities:
 - PSD: 2.5, 5, 10, 25
 - PSD-SJTH: 0.5, 1, 2, 5, 10, 20, 25, 30
 - PSD-SJTT: 0.2, 0.5, 1, 1.5, 2.5, 5, 10, 20, 25, 30, 50, 100 t
- Compact size with low profile
- Low deflection for high output
- Electroless nickel-plated alloy tool steel construction
- Off center load compensated
- OIML C3 available for the entire series
- **Optional**
 - PSD-SJTT and PSD-SJTH models have different mounting holes and capacities from default PSD – see below for details.



APPLICATIONS

- Testing machines
- Platform scales
- Hopper and vessel weighing
- Truck scales

DESCRIPTION

The model PSD is a precision shear web disk, a specialized compression load cell. A low profile design makes the PSD the most suitable application when height is a primary safety concern. The shear web design provides excellent performance even when side forces are inevitable in normal operations. A typical example would be in motor truck scales. The PSD is fully potted with special chemical compounds to the IP67 standard. This protects the cell from water and moisture attack. The PSD-SJTT and PSD-SJTH are low-profile compression disks specially designed for testing machines.

Outline drawings and specifications follow on next pages.

Precision Shear Web Disk

OUTLINE DIMENSIONS - PSD 2.5 TO 25 t

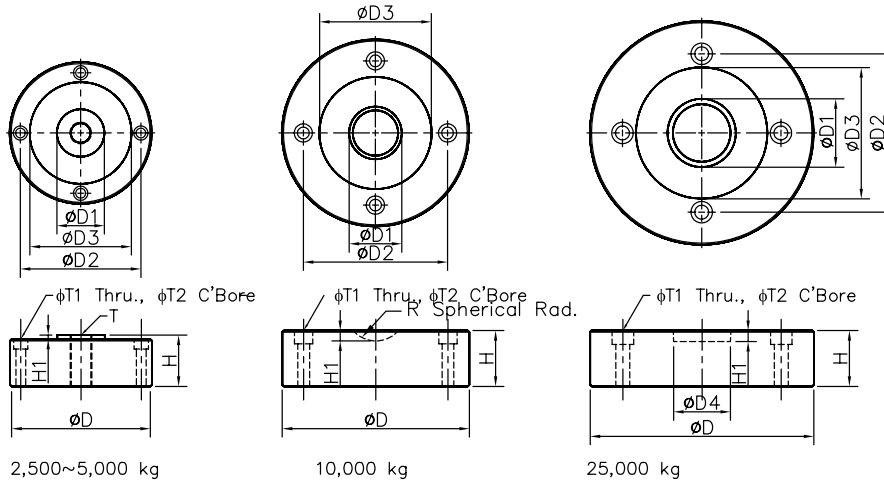

Wiring

- + Excitation Red
- Excitation Black
- + Signal Green
- Signal White

Please note:

The shape of the Model PSD varies between capacities. Please consult the dimensions table below carefully.

CAPACITY		D	D ₁	D ₂	D ₃	D ₄	H	H ₁	R	T	T ₁	T ₂
2.5 t / 5 t	mm	104.7	32	88.9	75.15	—	34.8	3.05	—	M16 × 1.5	7.2	10.5 × 7.2DP
	in	4.12	1.26	3.5	2.96	—	1.37	0.12	—		0.28	0.41 × 0.28DP
10 t	mm	138	38.9	106.4	82.8	—	41.1	7.62	22.2	—	8.7	13.5 × 9.7DP
	in	5.43	1.53	4.19	3.26	—	1.62	0.3	0.87	—	0.34	0.53 × 0.38DP
25 t	mm	165	50.4	116.8	96.92	42	41.1	8	—	—	10.3	18.5 × 10.2DP
	in	6.5	1.98	4.6	3.82	1.65	1.62	0.31	—	—	0.41	0.63 × 0.40DP

OUTLINE DIMENSIONS - PSD-SJTT 0.2 TO 30 t

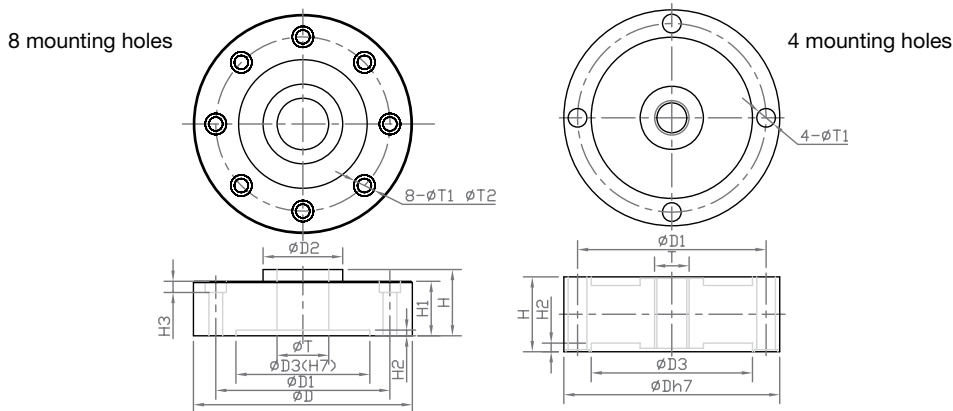

Wiring

- + Excitation Red
- Excitation Black
- + Signal Green
- Signal White

Please note:

The shape of the Model PSD varies between capacities. Please consult the dimensions table below carefully.

CAPACITY		D	D ₁	D ₂	D ₃	H	H ₁	H ₂	T	T ₁	T ₂	H ₃
0.2 t	mm	75	65.5	—	56	26	—	3	M12-6H	6.5	—	—
	in	2.95	2.58	—	2.20	1.02	—	0.12	—	0.25	—	—
0.5 / 1 t	mm	90	78	22	65	43	40	3	M12 × 1.75	6.6	10.5	6
	in	3.54	3.07	0.87	2.56	1.69	1.57	0.12	—	0.26	0.41	0.24
1.5 / 2.5 t	mm	105	89	32	75	35	32	3	M16 × 2	7.2	10.5	7.2
	in	4.13	3.5	1.26	2.95	1.38	1.26	0.12	—	0.25	0.41	0.28
5/10 t	mm	138	110	44	88	46	41	3	M27 × 2	13.2	19	12
	in	5.43	4.33	1.73	3.46	1.81	1.62	0.12	—	0.52	0.75	0.47
20/25/30 t	mm	165	130	55	96	50	41	3	M36 × 2	21	31	20
	in	6.5	5.11	2.17	3.78	1.97	1.62	0.12	—	0.83	1.22	0.79

Precision Shear Web Disk

OUTLINE DIMENSIONS – PSD-SJTT 50 AND 100 t

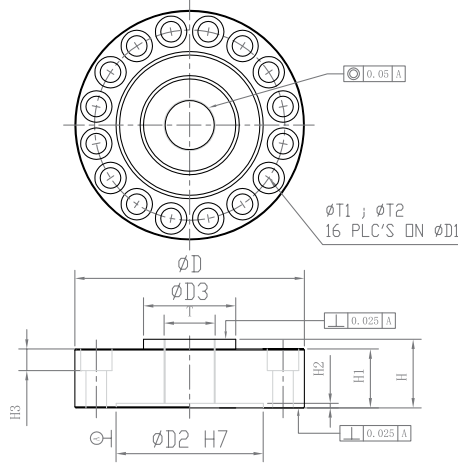

Wiring
 + Excitation Red
 - Excitation Black
 + Signal Green
 - Signal White

Please note:
 The shape of the Model PSD varies between capacities. Please consult the dimensions table below carefully.

CAPACITY		D	D ₁	D ₂	D ₃	H	H ₁	H ₂	H ₃	T	T ₁	T ₂
50 t	mm	234	194	150	94	60.0	55	4.7	22	M52 × 2-6H	21.0	32.0
	in	9.2	7.6	5.9	3.7	2.4	2.2	0.2	0.9		0.8	1.3
100 t	mm	258	218	174	120	60.0	57	3	22	M76 × 2	21.0	32.0
	in	10.2	8.6	6.9	4.72	2.4	2.24	0.12	0.9		0.8	1.3

OUTLINE DIMENSIONS – PSD-SJTH

500 kg to 2 t

5 to 30 t

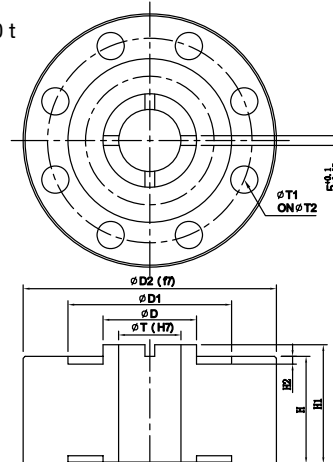
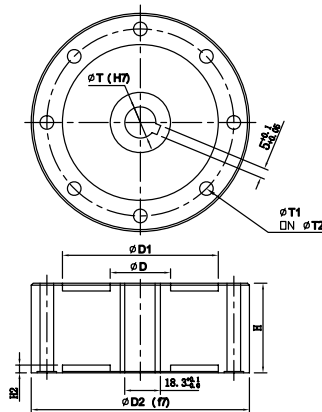

Wiring
 + Excitation Red
 - Excitation Black
 + Signal Green
 - Signal White

Please note:
 The shape of the Model PSD varies between capacities. Please consult the dimensions table below carefully.

CAPACITY		D	D ₁	D ₂	H	H ₁	H ₂	T	T ₁	T ₂
500 kg / 1 t / 2 t	mm	31	80	112	46	–	4	16	7.0	96.0
	in	1.22	3.15	4.41	1.81	–	0.16	0.63	0.28	3.78
5 / 10 t	mm	48	84	130	55	61	4	32	14.0	105.0
	in	1.89	3.31	5.12	2.17	2.4	0.16	1.26	0.43	4.13
20 / 25 / 30 t	mm	72	130	182	80.	86	4	39	15.0	154.0
	in	2.83	5.12	7.17	3.15	3.39	0.16	1.54	0.59	6.06

Precision Shear Web Disk

SPECIFICATIONS PSD AND PSD SJTH			
PARAMETER	VALUE		UNIT
Model	PSD	PSD SJTH	
Standard capacities	2.5, 5, 10, 25	0.5, 1, 2, 5, 10, 20, 25, 30	t
Rated output – R.O.	3 (±0.25%)		mV/V
Rated output tolerance	0.25		±% of rated output
Zero balance	±1	±2	±% of rated output
Non-linearity	0.025%	0.05%	±% of rated output
Hysteresis	0.025%	0.05%	±% of rated output
Non-repeatability	0.02%		±% of rated output
Creep error (20 minutes)	0.03%		±% of rated output
Zero return (20 minutes)	0.03%		±% of rated output
Compensated temperature range	-10 to +40		°C
Operating temperature range	-20 to +60		°C
Safe overload	150		% of R.C.
Ultimate overload	300		% of R.C.
Excitation, recommended	10		VDC or VAC RMS
Excitation, maximum	15		VDC or VAC RMS
Input impedance	385±5	385±5	Ω
Output impedance	350±3	350±3	Ω
Insulation resistance	>5000		MΩ
Construction	Nickel-plated alloy steel	Nickel-plated alloy steel	
Environmental protection	IP67		

SPECIFICATIONS PSD-SJTT				
PARAMETER	VALUE			UNIT
Model	PSD-SJTT	PSD-SJTT Aluminium	PSD-SJTT 50 t & 100 t Models	
Standard capacities	0.5, 1, 1.5, 2.5, 5, 10, 20, 25, 30	0.2	50, 100	t
Rated output – R.O.	3 (±0.25%)	2 (±0.25%)	50 t: 3 (±0.25%) 100 t: 2 (±0.25%)	mV/V
Rated output tolerance	0.25			±% of rated output
Zero balance	±1			±% of rated output
Non-linearity	0.05%	0.05%	0.10%	±% of rated output
Hysteresis	0.05%	0.05%	0.10%	±% of rated output
Non-repeatability	0.02%			±% of rated output
Creep error (20 minutes)	0.03%			±% of rated output
Zero return (20 minutes)	0.03%			±% of rated output
Compensated temperature range	-10 to +40			°C
Operating temperature range	-20 to +60			°C
Safe overload	150			% of R.C.
Ultimate overload	300			% of R.C.
Excitation, recommended	10			VDC or VAC RMS
Excitation, maximum	15			VDC or VAC RMS
Input impedance	385±5	385±5	770±10	Ω
Output impedance	350±3	350±3	700±0	Ω
Insulation resistance	>5000			MΩ
Construction	Nickel-plated alloy steel	Aluminium	Nickel-plated alloy steel	
Environmental protection	IP67			

Precision Shear Web Disk

SPECIFICATIONS ALL MODELS			
PARAMETER	VALUE		UNIT
	C3	Non-approved	
NTEP/OMIL accuracy class			
Maximum no. of intervals (n)	3000	1000	
Y = E_{max}/V_{min}	8000	5000	Maximum available
Temperature effect on min. dead load output	0.0017	0.0026	±% of applied load/°C
Temperature effect on sensitivity	0.001	0.0015	±% of applied load/°C

All specifications subject to change without notice.



Disclaimer

ALL PRODUCTS, PRODUCT SPECIFICATIONS AND DATA ARE SUBJECT TO CHANGE WITHOUT NOTICE.

Vishay Precision Group, Inc., its affiliates, agents, and employees, and all persons acting on its or their behalf (collectively, "VPG"), disclaim any and all liability for any errors, inaccuracies or incompleteness contained herein or in any other disclosure relating to any product.

The product specifications do not expand or otherwise modify VPG's terms and conditions of purchase, including but not limited to, the warranty expressed therein.

VPG makes no warranty, representation or guarantee other than as set forth in the terms and conditions of purchase. **To the maximum extent permitted by applicable law, VPG disclaims (i) any and all liability arising out of the application or use of any product, (ii) any and all liability, including without limitation special, consequential or incidental damages, and (iii) any and all implied warranties, including warranties of fitness for particular purpose, non-infringement and merchantability.**

Information provided in datasheets and/or specifications may vary from actual results in different applications and performance may vary over time. Statements regarding the suitability of products for certain types of applications are based on VPG's knowledge of typical requirements that are often placed on VPG products. It is the customer's responsibility to validate that a particular product with the properties described in the product specification is suitable for use in a particular application. You should ensure you have the current version of the relevant information by contacting VPG prior to performing installation or use of the product, such as on our website at vpgsensors.com.

No license, express, implied, or otherwise, to any intellectual property rights is granted by this document, or by any conduct of VPG.

The products shown herein are not designed for use in life-saving or life-sustaining applications unless otherwise expressly indicated. Customers using or selling VPG products not expressly indicated for use in such applications do so entirely at their own risk and agree to fully indemnify VPG for any damages arising or resulting from such use or sale. Please contact authorized VPG personnel to obtain written terms and conditions regarding products designed for such applications.

Product names and markings noted herein may be trademarks of their respective owners.

Copyright Vishay Precision Group, Inc., 2014. All rights reserved.