

Digital Compression Load Cell

FEATURES

- Capacities: 30, 40 and 50 ton
- Digital output via RS-485 or RS-422 interface
- Self-aligning, stainless steel single column
- Hermetically sealed, IP66 and IP68
- Certified to OIML R-60, 4000d
- Internal diagnostics
- Internal lightning protection
- Maximum transmission distance 1200m
- **Optional**
 - Self-aligning mount available
 - Operation manual - SLC

APPLICATIONS

- Weighbridges
- Silo hopper weighing

DESCRIPTION

The DSC, Digital Single Column, is a stainless steel compression load cell with a digital output.



This digital output enables the user to communicate with each DSC independent of the others in the system, thus offering advantages in system setup, system control, corner correction, fault finding and load cell replacement.

This product is suitable for use in road and rail weighbridges and process weighing applications.

The welded construction and built-in surge protection ensure that this product can be used successfully in harsh environments.

OUTLINE DIMENSIONS in millimeters

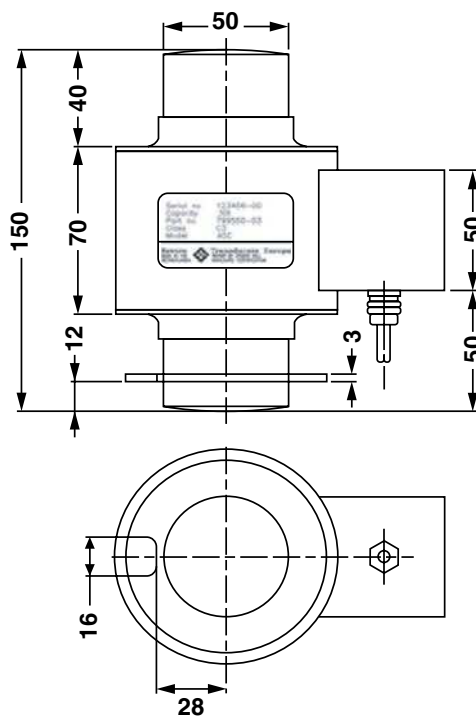

Cable specifications

Cable length:	15m
Excitation +	Green
Excitation -	Black
Rx +	Yellow
Rx -	Blue
Tx +	Red
Tx -	White
Shield	Transparent

Digital Compression Load Cell

SPECIFICATIONS				
PARAMETER	VALUE			UNIT
Standard capacities (E _{max})	30, 40, 50			ton
Accuracy class according to OIML R-60	Non-approved	C3	C4	
Maximum no. of verification intervals (n)		3000	4000	
Minimum verification interval (V _{min} =E _{max} /Y)		E _{max} /6,000	E _{max} /8,000	
Minimum verification interval, type MR		E _{max} /15,000	E _{max} /20,000	
Rated output (FSO)	240,000			counts
Tolerance on rated output	200			±counts
Zero balance	200			±counts
Combined error	0.0500	0.023	0.018	±% FSO
Non-repeatability	0.070	0.035	0.026	±% FSO
Minimum dead load output return	0.0500	0.017	0.013	±% FSO
Minimum dead load output return, type MI7.5	-	0.0067	0.0067	±% FSO
Creep error (30 minutes)	0.0600	0.025	0.0184	±% FSO
Creep error (20–30 minutes)	0.0200	0.0053	0.0039	±% FSO
Temp. effect on min. dead load output	0.0250	0.0117	0.0088	±% FSO/5°C
Temp. effect on min. dead load output MR		0.0047	0.0035	±% FSO/5°C
Temperature effect on sensitivity	0.0250	0.0088	0.0065	±% FSO/5°C
Compensated temperature range	-10 to +40			°C
Operating temperature range	-40 to +80			°C
Storage temperature range	-40 to +90			°C
Minimum dead load	0			% E _{max}
Safe dead load	150			% E _{max}
Ultimate load	300			% E _{max}
Deflection at E _{max}	0.50			mm
Excitation voltage	12.5 to 18.0			VDC
Recommended excitation voltage	15			VDC
Maximum current consumption	80			mA
Start up current	150			mA
Insulation resistance	>5000			MΩ
Element material (DIN)	Stainless steel 1.4542			
Sealing (DIN 40.050 / EN60.529 / IEC 529)	IP66 and IP68			
Signal update per second	25			
Baudrate	9600			Bits/s
Transmission type	Asynchronous serial transmission			
Start bits	1			
Data bits	7			
Stop bits	1			
Parity	Odd			
Maximum transmission cable length	1200			m
Data transmission interface	RS422 (4 communication wires) RS485 (2 communication wires)			

FSO— Full Scale Output

Correct mounting of the load cells is essential to ensure optimum accuracy and performance. Further information is available upon request.

All specifications subject to change without notice.

Disclaimer

ALL PRODUCTS, PRODUCT SPECIFICATIONS AND DATA ARE SUBJECT TO CHANGE WITHOUT NOTICE.

Vishay Precision Group, Inc., its affiliates, agents, and employees, and all persons acting on its or their behalf (collectively, "VPG"), disclaim any and all liability for any errors, inaccuracies or incompleteness contained herein or in any other disclosure relating to any product.

The product specifications do not expand or otherwise modify VPG's terms and conditions of purchase, including but not limited to, the warranty expressed therein.

VPG makes no warranty, representation or guarantee other than as set forth in the terms and conditions of purchase. **To the maximum extent permitted by applicable law, VPG disclaims (i) any and all liability arising out of the application or use of any product, (ii) any and all liability, including without limitation special, consequential or incidental damages, and (iii) any and all implied warranties, including warranties of fitness for particular purpose, non-infringement and merchantability.**

Information provided in datasheets and/or specifications may vary from actual results in different applications and performance may vary over time. Statements regarding the suitability of products for certain types of applications are based on VPG's knowledge of typical requirements that are often placed on VPG products. It is the customer's responsibility to validate that a particular product with the properties described in the product specification is suitable for use in a particular application. You should ensure you have the current version of the relevant information by contacting VPG prior to performing installation or use of the product, such as on our website at vpgsensors.com.

No license, express, implied, or otherwise, to any intellectual property rights is granted by this document, or by any conduct of VPG.

The products shown herein are not designed for use in life-saving or life-sustaining applications unless otherwise expressly indicated. Customers using or selling VPG products not expressly indicated for use in such applications do so entirely at their own risk and agree to fully indemnify VPG for any damages arising or resulting from such use or sale. Please contact authorized VPG personnel to obtain written terms and conditions regarding products designed for such applications.

Product names and markings noted herein may be trademarks of their respective owners.

Copyright Vishay Precision Group, Inc., 2014. All rights reserved.