

Wymiary

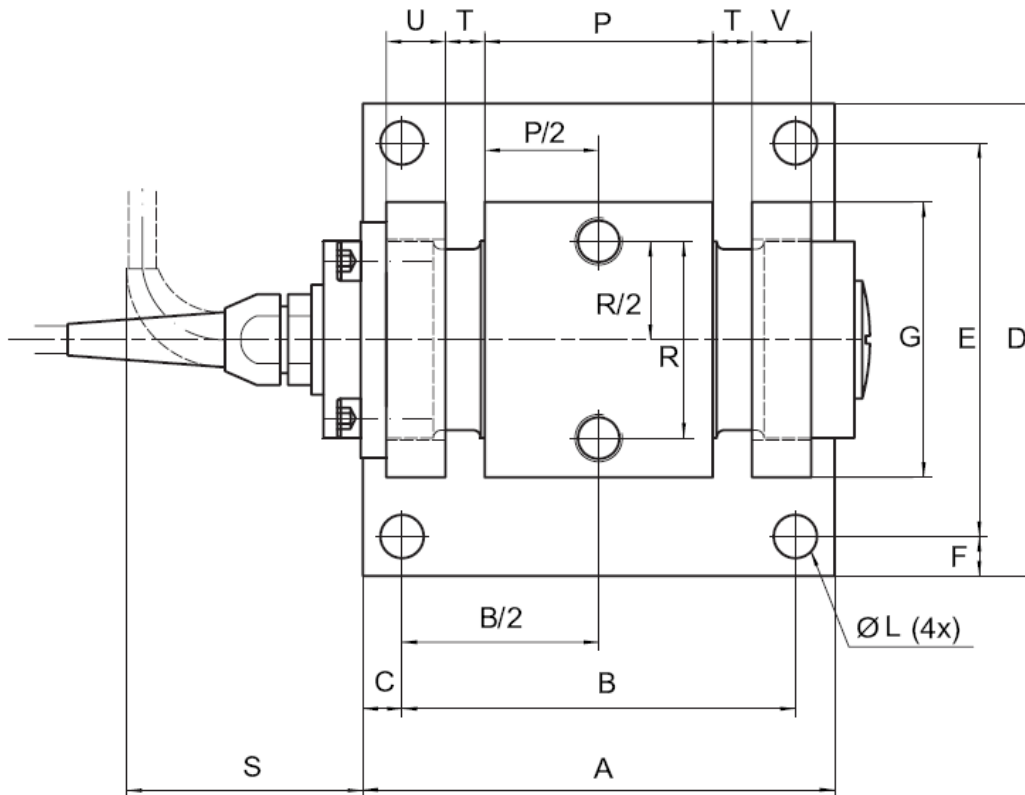

Zakres kN	A	B	C	D	E	F	G	H ± 1	J	K $_{-1}^0$	$\text{Ø}L$	M	N	P	R	S	T	U $_{-1}^0$	V $_{-1}^0$
10-20-50	120	100	10	120	100	10	70	89	70	15	11	M12	18	33	50	47	10	15	15
100	120	100	10	120	100	10	70	89	70	15	11	M12	18	48	50	60	10	20	20
200	140	90	25	170	140	15	100	135	100	24	14	M16	28	48	70	50	10	30	20

Sposób rozmieszczenia czujników pomiarowych

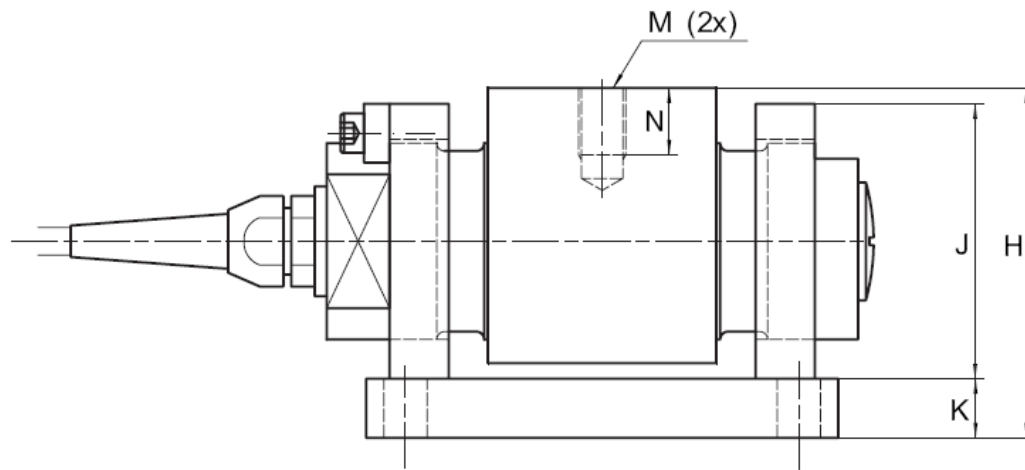