



Rotating Vane Flow Meter for liquids



measuring
•
monitoring
•
analysing

DRH

Model: DRH-...E/...G



Model: DRH-...L

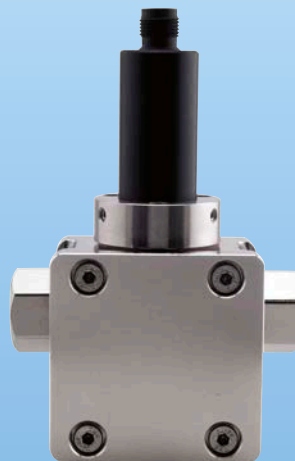

Model: DRH-...C



- Measuring ranges:
0.2 - 0.8 ... 2.5 - 50 l/min water
- Linearity:
±2.5 % of full scale
- p_{\max} : 100 bar; t_{\max} : 80 °C
- Connection:
G 3/8, G 1 female,
3/8" NPT, 1" NPT female
- Material:
brass, stainless steel, POM, PVDF
- Viscosity range: low viscous
- Output:
pulses, 4 - 20 mA,
switching outputs
- Counter/batcher



S4

KOBOLD companies worldwide:

AUSTRALIA, AUSTRIA, BELGIUM, BULGARIA, CANADA, CHINA, CZECHIA, FRANCE, GERMANY, GREAT BRITAIN, HUNGARY, INDIA, INDONESIA, ITALY, MALAYSIA, MEXICO, NETHERLANDS, PERU, POLAND, REPUBLIC OF KOREA, SPAIN, SWITZERLAND, THAILAND, TUNISIA, TURKEY, USA, VIETNAM

KOBOLD Messring GmbH
Nordring 22-24
D-65719 Hofheim/Ts.
Head Office:
+49(0)6192 299-0
+49(0)6192 23398
info.de@kobold.com
www.kobold.com

Description

KOBOLD rotating vane flow meters series DRH are used for measuring and monitoring low viscous liquids. Series DRH flow meters are working according the well-known rotating vane principle. A magnet fitted in the vane and hermetically sealed from the medium transfers non-contacting the rotary motion to a Hall-effect sensor mounted in the housing. The sensor converts the rotary motion which is proportional to the flow to a frequency signal. A series-connected electronics unit converts the signal to an analogue output, limit contacts or display. These devices can be adapted to prevailing plant conditions with the 360° rotatable screw connections.

Fields of Application

- Cooling water monitoring
- Agricultural machinery
- PCB board industry

Electrical Connection

DRH-...F., DRH-...L3... 3-wire

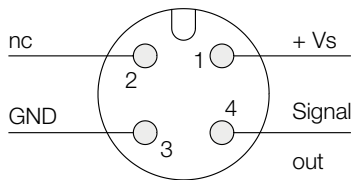

DRH-...L342... 2-wire

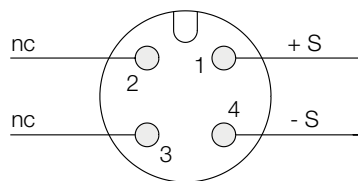

DRH-...L4...

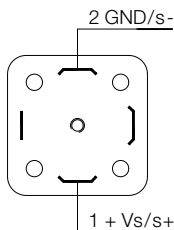

DRH-...C...

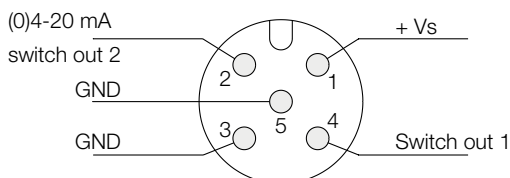

DRH-...E14R, DRH-...G14R cable connection

Wire number	DRH-...E14R Counter electronics	DRH-...G14R Dosing electronics
1	+24 V _{DC}	+24 V _{DC}
2	GND	GND
3	4-20 mA	4-20 mA
4	GND	GND
5	do not connect	Control 1*
6	Reset part quantity	Control 2*
7	Relay S1	Relay S1
8	Relay S1	Relay S1
9	Relay S2	Relay S2
10	Relay S2	Relay S2

Control 1 <-> GND: Start-Dosing
 Control 2 <-> GND: Stop-Dosing
 Control 1 <-> Control 2: Reset-Dosing

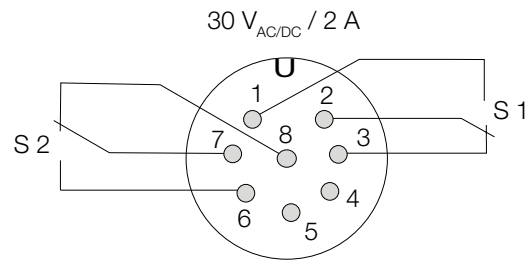

Plug Connection

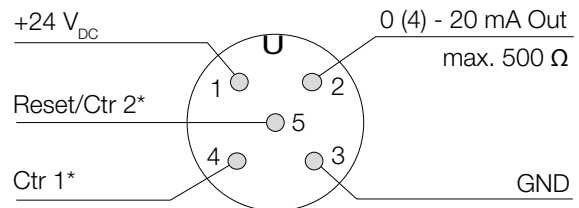



Technical Details

Material combinations:	see order details
Max. operating pressure:	see order details
Max. temperature:	see order details
Linearity:	±2.5% of full scale ±5% of full scale (DRH-...F300)
Electrical connection:	plug connector DIN 43 650, plug connector M12x1, cable
Pressure loss:	max. 1 bar at max. range
Protection:	IP 65

Electronics

● Frequency output (...F300)*

Power supply:	12-28 V _{DC}
Power consumption:	10 mA
Pulse output:	PNP, open collector max. 25 mA
Electrical connection:	plug connector M12x1

● Frequency output with frequency divider

Power supply:	24 V _{DC} ±20%
Power consumption:	15 mA
Pulse output:	PNP, open collector, max. 25 mA
Electrical connection:	plug connector M12x1
Division ratio:	1 ... 1/128, factory set

● Analogue output (Option plug-on display)

Power supply:	24 V _{DC} ±20%
Output:	0 - 20 mA or 4 - 20 mA, 2-wire or 3-wire
Max. load:	500 Ω
Electrical connection:	plug connector M12x1 or DIN 43650
Option:	plug-on display (with plug connector DIN 43650 and output 4 - 20 mA only), 2-wire

● Compact electronics

Display:	3-segment LED
Analogue output:	(0)4...20 mA adjustable, max. 500 W
Switching outputs:	1 (2) semiconductor PNP or NPN factory set
Contact operation:	N/C / N/O contact frequency programmable
Setting:	with 2 buttons
Power supply:	24 V _{DC} ±20%, 3-wire technology approx. 100 mA
Electrical connection:	plug connector M12x1

* uncalibrated signal output

DRH-...Exxx (Counter electronics)

Display:	LCD, 2 x 8 digit, illuminated total, part and flow quantities, units selectable
Quantity meter:	8-digit
Analogue output:	(0)4...20 mA adjustable
Load:	max. 500 Ω
Switching output:	2 relays, max. 30 V _{AC/DC} /2 A/60 VA
Settings:	via 4 buttons
Functions:	reset, MIN/MAX memory, flow monitor, monitoring for part and total quantity, language
Power supply:	24 V _{DC} ±20%, 3-wire
Power consumption:	approx. 150 mA
Electrical connections:	cable connection or M 12 plug

More technical details see data sheet ZED

DRH-...Gxxx (Dosing electronics)

Display:	LCD, 2 x 8 digit, illuminated dosing-, total-, and flow quantity, units selectable
Quantity meter:	8-digit
Dosage:	5-digit
Analogue output:	(0)4...20 mA adjustable
Load:	max. 500 Ω
Switching output:	2 relays, max. 30 V _{AC/DC} /2 A/60 VA
Settings:	via 4 buttons
Functions:	dosing (relay S2), start, stop, reset, fine dosing, correction amount, flow switch, total quantity, language
Power supply:	24 V _{DC} ±20%, 3-wire
Power consumption:	approx. 150 mA
Electrical connection:	cable connection or M12 plug

More technical details see data sheet ZED



Order Details (Example: DRH-1 1 05 N3 F300)

Measuring range		Orifice diameter [mm]	Model	Connection		Evaluating electronics
Water [l/min]	Frequency [Hz] at F.S. ³⁾			Standard female	Special female	
0.2-0.8	63	1	DRH-1X05..	..G3..=G%	..N3..= 3/8" NPT	Frequency output ..F300 = Frequency output, plug connector M12x1 ..F320 = Frequency divider 1:2, plug connector M12x1 ..F340 = Frequency divider 1:4, plug connector M12x1 ..F390 = Frequency divider 1...1/128, plug connector M12x1
0.2-2.0	50	2	DRH-1X10..	..G6..=G1	..N6..= 1" NPT	Analogue output ..L303 = 0-20 mA output, 3-wire, M12x1 plug connector ..L342 = 4-20 mA output, 2-wire, M12x1 plug connector ..L343 = 4-20 mA output, 3-wire, M12x1 plug connector ..L442 = 4-20 mA output, 2-wire, plug connector DIN 43 650
0.3-2.8	123	2	DRH-1X15..	..G3..=G%	..N3..= 3/8" NPT	Compact electronics¹⁾ ..C30R = LED display, 2 x open Collector, PNP, plug connector M12x1 ..C30M = LED display, 2 x open Collector, NPN, plug connector M12x1 ..C34P = LED display, 4-20 mA, 1 x open Collector PNP, plug connector M12x1 ..C34N = LED display, 4-20 mA, 1 x open Collector NPN, plug connector M12x1
0.25-5.0	78	3	DRH-1X20..	..G6..=G1	..N6..= 1" NPT	
0.5-6.0	166	3	DRH-1X25..	..G3..=G%	..N3..= 3/8" NPT	Counter electronics ..E14R = LCD, 0(4)-20 mA, 2 x relay, 1.5 m cable ..E34R = LCD, 0(4)-20 mA, 2 x relay, M12 plug ..E94R = LCD, 0(4)-20 mA, 2 x relay, cable >1.5 m ²⁾
1.0-15	145	5	DRH-1X30..	..G6..=G1	..N6..= 1" NPT	
1.0-16	225	5	DRH-1X35..	..G3..=G%	..N3..= 3/8" NPT	Dosing electronics ..G14R = LCD, 0(4)-20 mA, 2 x relay, 1.5 m cable ..G34R = LCD, 0(4)-20 mA, 2 x relay, M12 plug ..G94R = LCD, 0(4)-20 mA, 2 x relay, cable >1.5 m ²⁾
1.0-26	240	7	DRH-1X40..	..G3..=G%	..N3..= 3/8" NPT	
2.0-36	228	9	DRH-1X45..	..G6..=G1	..N6..= 1" NPT	
2.5-50	220	10	DRH-1X50..	..G6..=G1	..N6..= 1" NPT	

¹⁾ Please specify flow direction in writing

²⁾ Please specify cable length in writing

³⁾ Frequency deviation at F. S. (uncalibrated output): ±3 %

Material Combinations (Please enter order code instead of X "model")

Device parts	Order code: 1	Order code: 2	Order code: 4	Order code: 5	Order code: 7	Order code: 8	Order code: 9
Housing incl. process connection	Brass, nickel-pl.	Brass, nickel-pl.	1.4404	1.4404	POM	POM	PVDF
Housing cover	PMMA	Brass, nickel-pl.	PMMA	1.4404	PMMA	POM	PVDF
Seal	NBR	NBR	FPM	FPM	NBR	NBR	FPM
Rotating vane	PTFE	PTFE	PTFE	PTFE	PTFE	PTFE	PTFE
Axle	Ceramic	Ceramic	Ceramic	Ceramic	Ceramic	Ceramic	Ceramic
Bearing	PTFE	PTFE	PTFE	PTFE	PTFE	PTFE	PTFE
p_{max} :	16 bar	100 bar	16 bar	100 bar	16 bar	16 bar	16 bar
t_{max} :	80 °C	80 °C	80 °C	80 °C	80 °C	80 °C	80 °C
Weight (3/8")	850 g	1000 g	900 g	1050 g	250 g	250 g	300 g
Weight (1")	1600 g	2000 g	1600 g	2000 g	400 g	400 g	500 g

Weight

Weight (Sensor)
+ Weight (electronics)
Total weight

Sensor Weight

See material combination

Electronic Weight

Frequency output: approx. 35 g
Analogue output (...L3...): approx. 35 g
Analogue output (...L4...): approx. 100 g
Compact electronics: approx. 650 g
Counter electronics: approx. 250 g
Dosing electronics: approx. 250 g

Dimensions

Model: DRH-F3..., DRH-...L (with analogue output)

Model: DRH-...L442 (with analogue output)

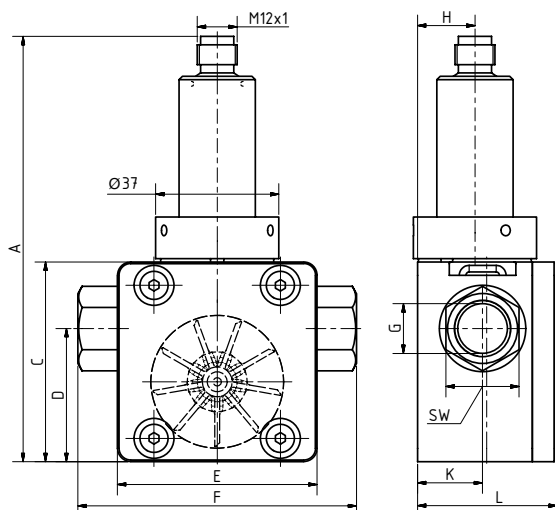

G	A	C	D	E	F	H	K	L	SW
3/8	128	60	40	60	84	17,5	19,5	42	22
1	138	70	42	70	110	22,5	22,5	53	41

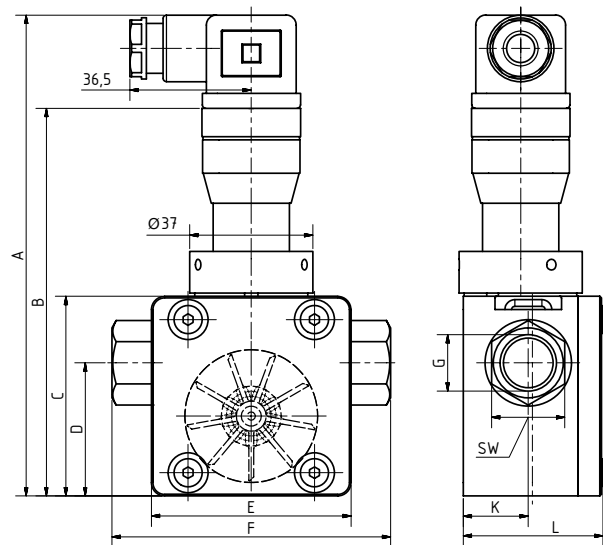

G	A	B	C	D	E	F	K	L	SW
3/8	145	117	60	40	60	84	19,5	42	22
1	155	127	70	42	70	110	22,5	53	41

Model: DRH-...C
(with compact electronics)

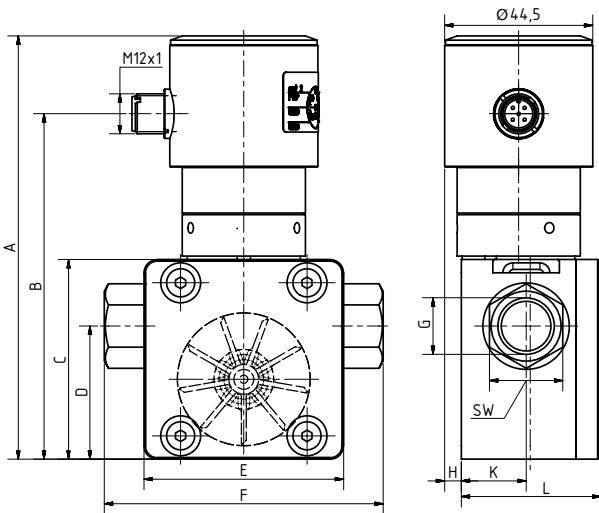

G	A	B	C	D	E	F	H	K	L	SW
3/8	128	104	60	40	60	84	5	19,5	42	22
1	138	114	70	42	70	110	-	22,5	53	41

Typ DRH-...E/G
(counter electronics / dosing electronics)

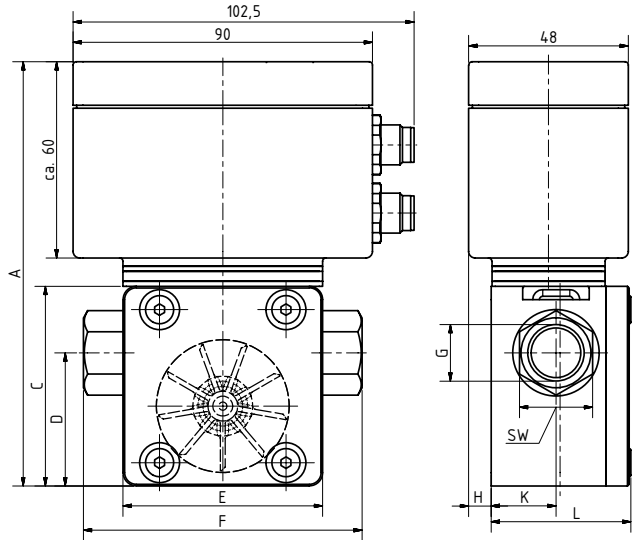

G	A	C	D	E	F	H	K	L	SW
3/8	128	60	40	60	84	7	19,5	42	22
1	138	70	42	70	110	2	22,5	53	41